

LECTURE 39 – SINGLE ACTUATOR CIRCUITS

SELF EVALUATION QUESTIONS AND ANSWERS

1: Study the following given circuit. Label all the components. Explain what happens if 1S1 or 1S2 is pressed. How cylinder is retracted.

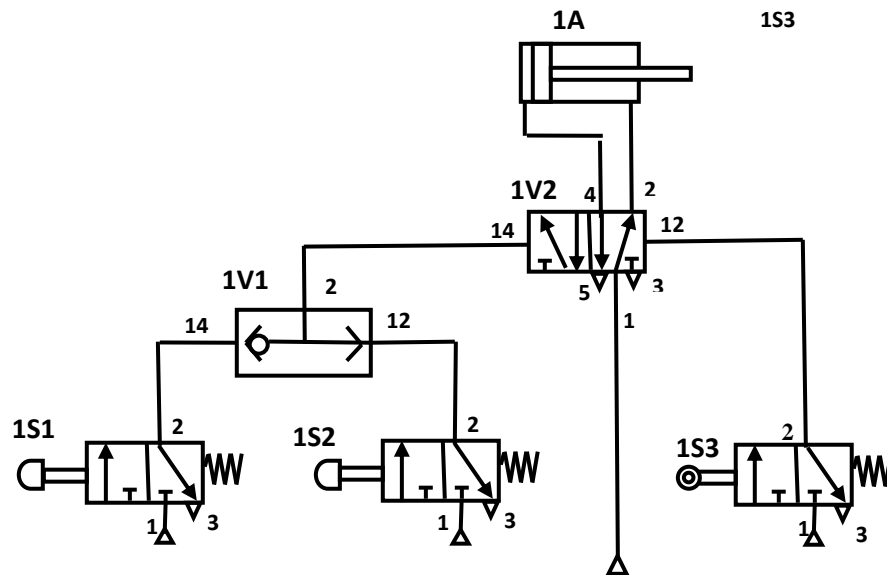

2: A double acting cylinder is to be advanced using three hand operated valves which are positioned at different locations from the cylinder. If any of three push buttons are pressed, cylinder must extend. Cylinder must be in retracted condition if all push buttons are not pressed.

3: A double acting cylinder is to extend and clamp a work piece when two push button valves are pressed simultaneously. For safety reasons, these push buttons valves are installed such a way that both valves cannot be operated with one hand, that is, the both the hands must be used to operate these two valves. The cylinder is to retract when a one or two push button is released. Develop a pneumatic circuit to implement the given control task using AND logic

4: A currency coin is embossed using a die driven by a double acting cylinder. The die is to advance and emboss the coin when a push button is operated. The return of the die is to be effected when a preset pressure is reached. The embossing pressure is to be adjustable so that different coins can be embossed in the same machine.

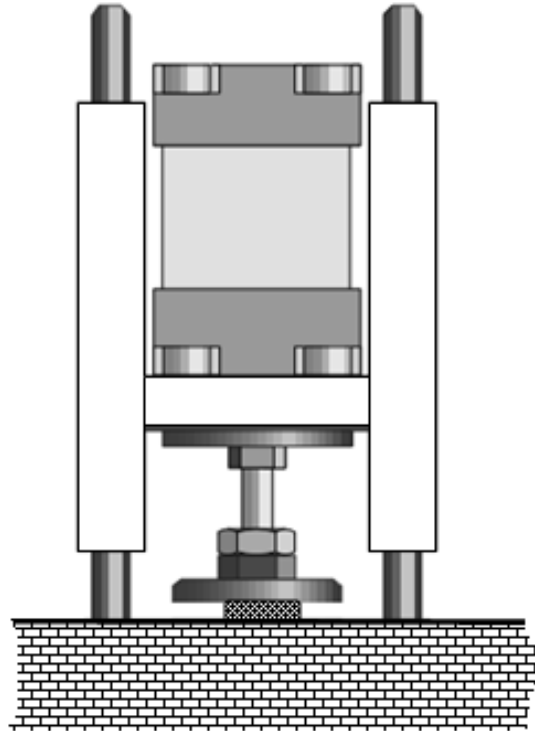

Q1 Solution: IS1 and IS2 are 3/2 direction control valves- push button operated
 IS3 is 3/2 DCV with limit switch
 IV1 is OR valve
 IV2 is 5/2 DCV – pilot operated
 1A is double acting cylinder

Working: If one of the push button (IS1 or IS2) is pressed, then there is an output at OR valve. OR valve will actuate 5/2 DCV and cylinder moves forward. The cylinder will fully extend, since the effect of the signal at input 14 of the 5/2 way double pilot valve 1V2 is maintained until a signal is applied at input 12. As soon as the piston rod has reached the forward end position, the limit switch IS3 generates a signal at input 12, and the valve 1V2 is reversed. The retracted end position of piston rod can also be sensed. This requires an additional limit switch.

Q2 Solution

Shuttle valves can be used to create this OR logic circuit.

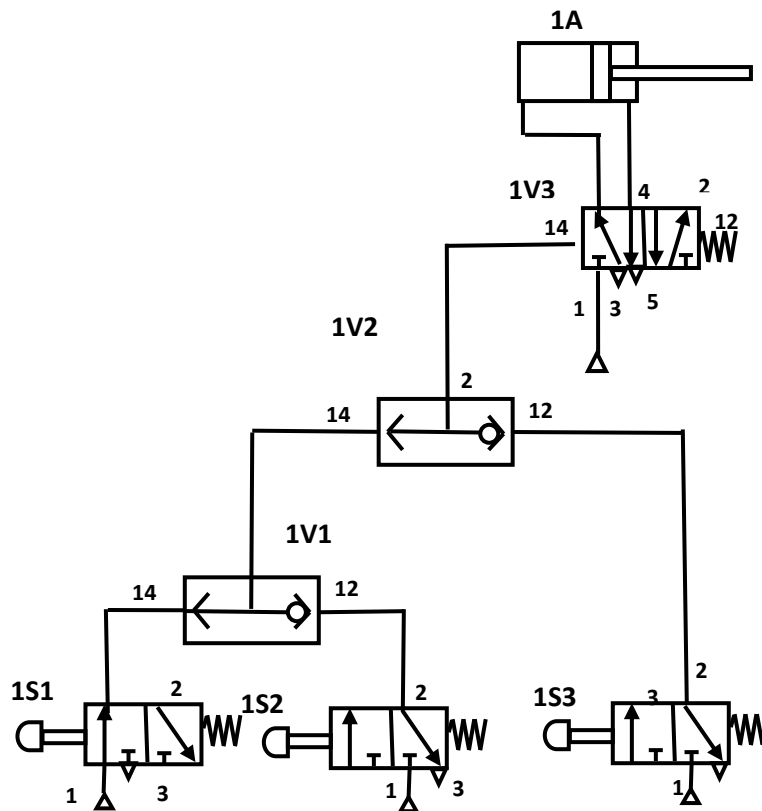

When any one of 3/2 valve (IS1, IS2, and IS3) is operated, the pilot air is available at 14 of the valve IV3 and cylinder extends. If all three valves (ISI, IS2 and IS3) are not pressed, then cylinder will be in retracted position.

Q3 Solution

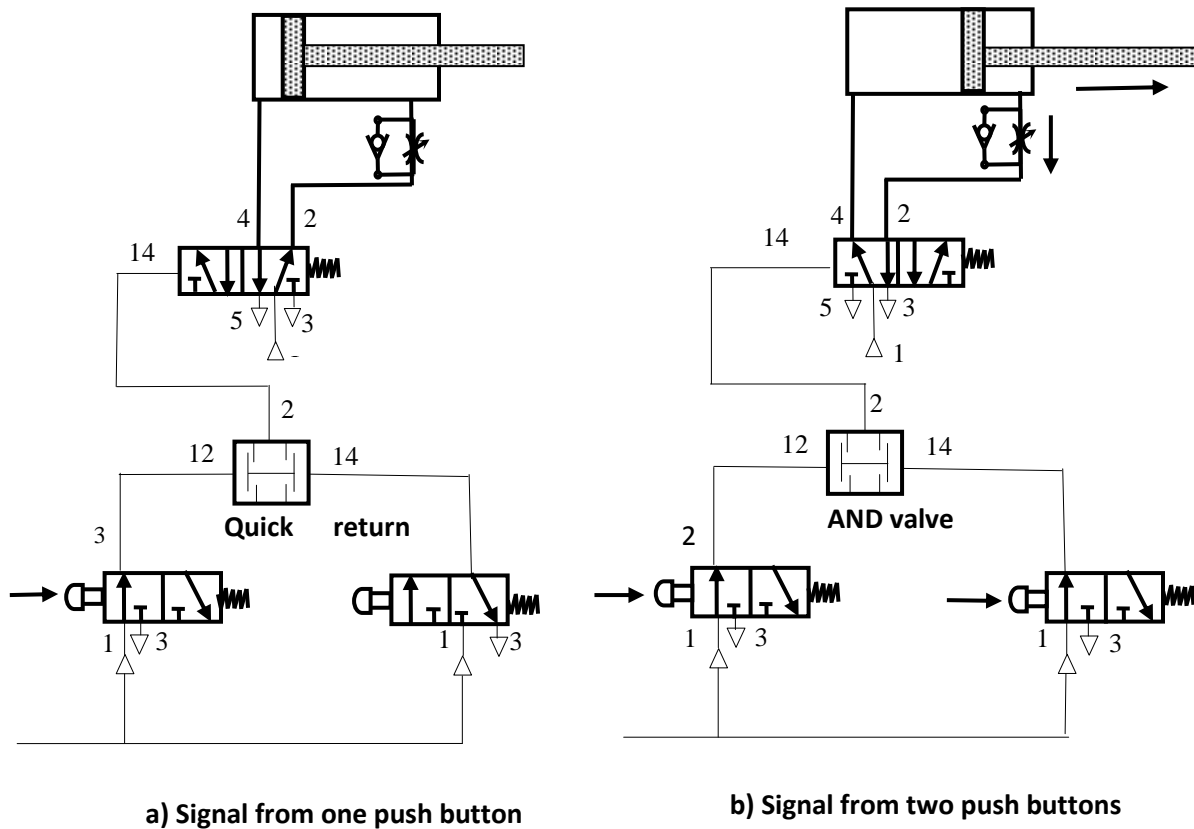

The above circuit is well known two hand safety circuit. This means that an operator can operate the machine for clamping the work piece only by pressing the two push buttons simultaneously and he has to use both his hands to do this. The two positions of the pneumatic circuit for the control task, with signal input from only one push button and signal input from two push button valve are shown in Figure ,, The double acting cylinder does not extend when only one push button valve is pressed Figure(a). This cylinder extends when both push button valves are pressed simultaneously as shown in Figure (b).

Q4 Solution

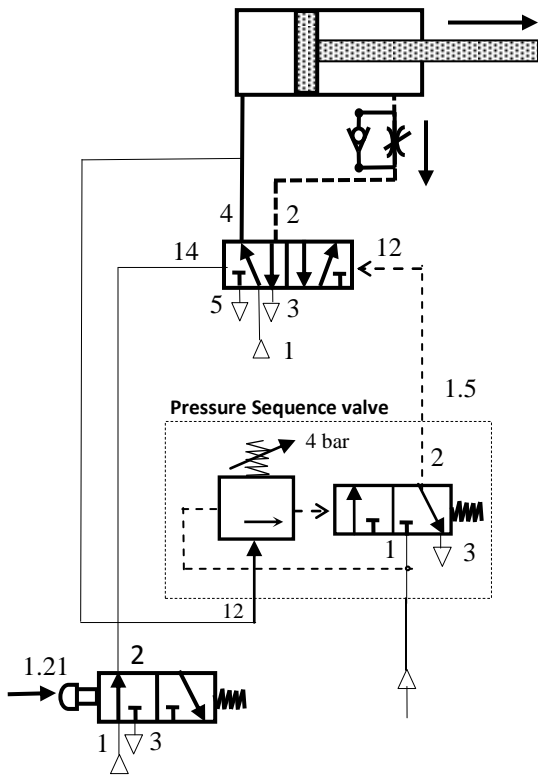

a) Cylinder extending

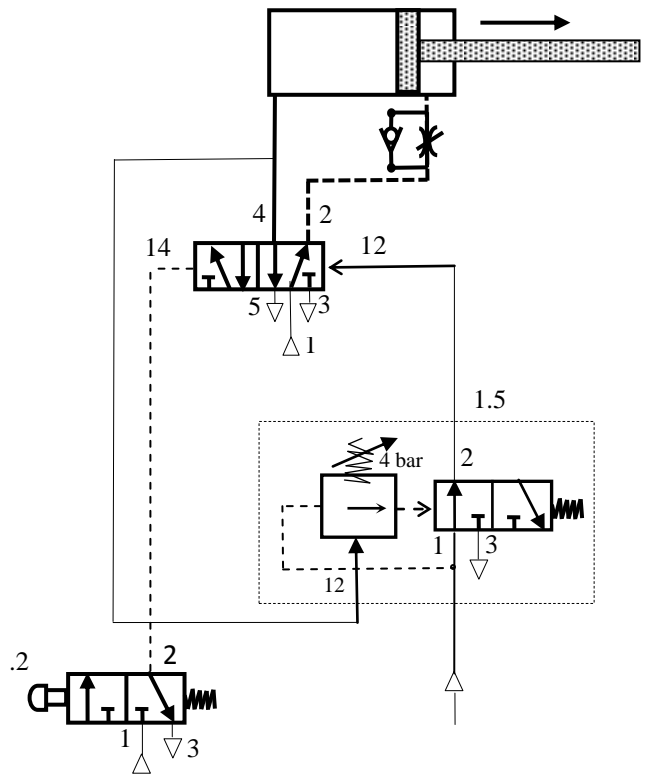

a) Cylinder fully extended